

PERPENDICULAR CURB RAMP

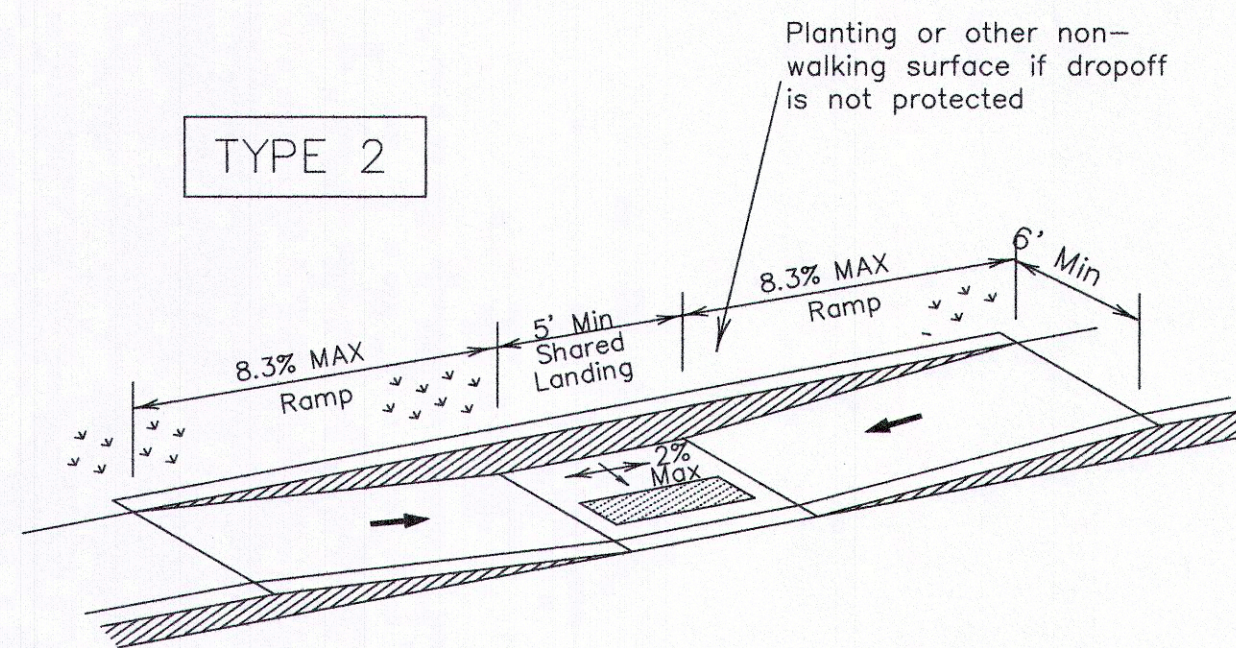

PARALLEL CURB RAMP
(Use only where water will not pond in the landing)

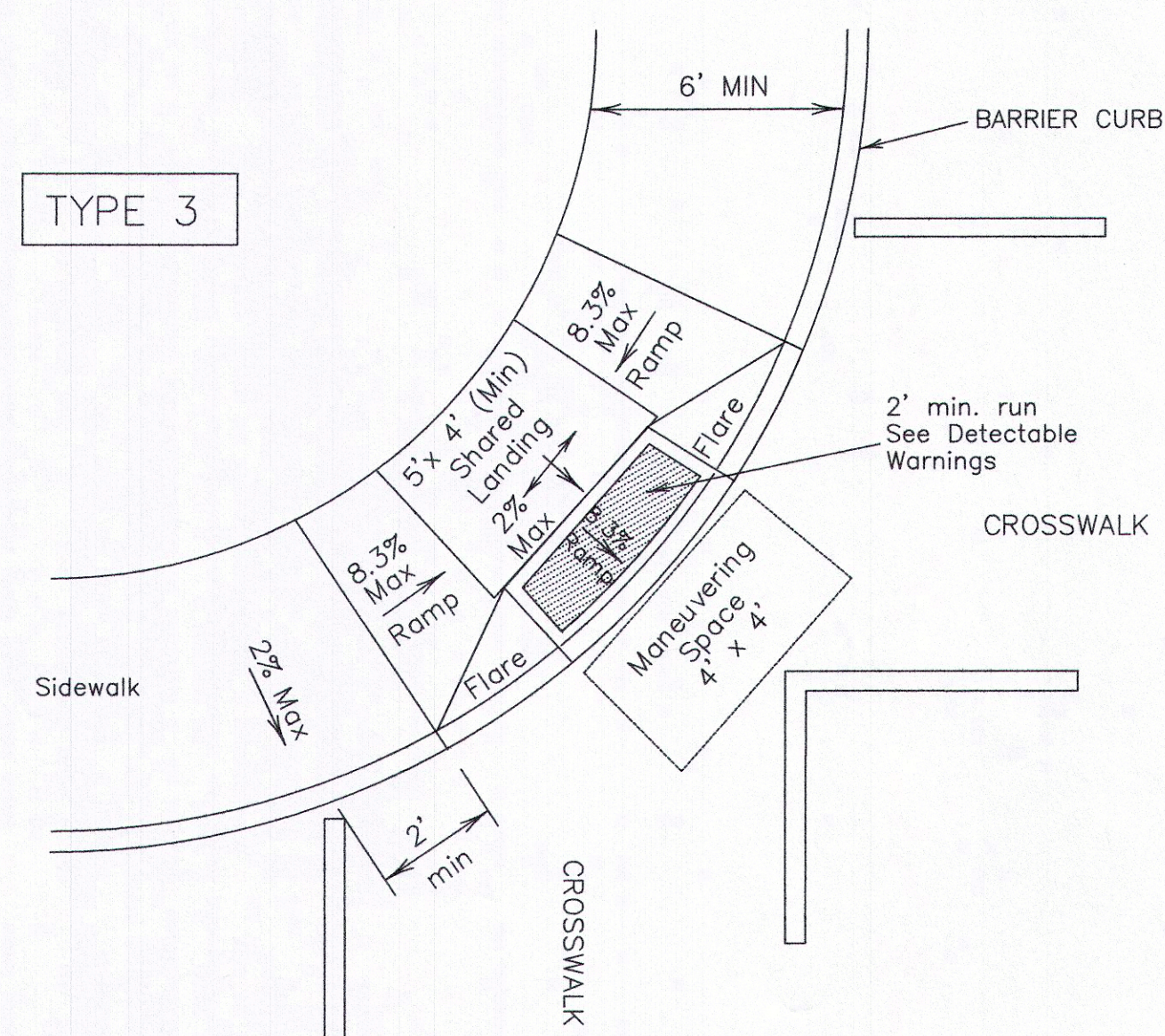

DIAGONAL COMBINATION CURB RAMP
Perpendicular to the Tangent of the Curb Radius and Contained in Crosswalk

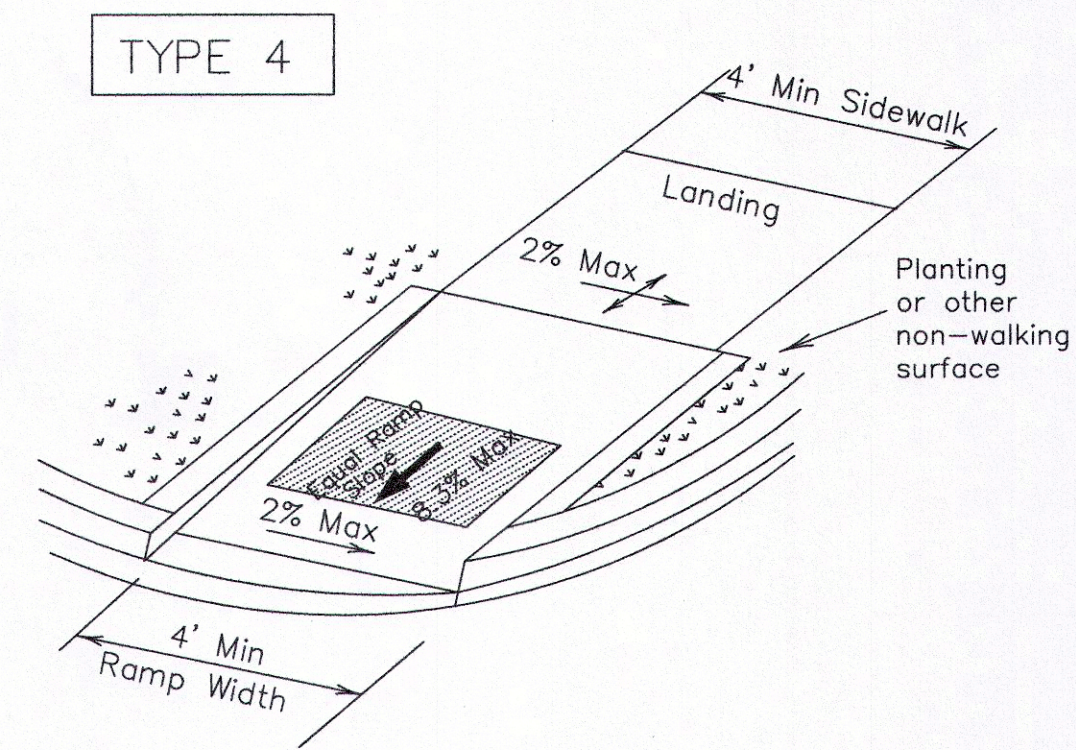

DIRECTIONAL RAMP WITHIN RADIUS
(Sidewalk set back from curb)

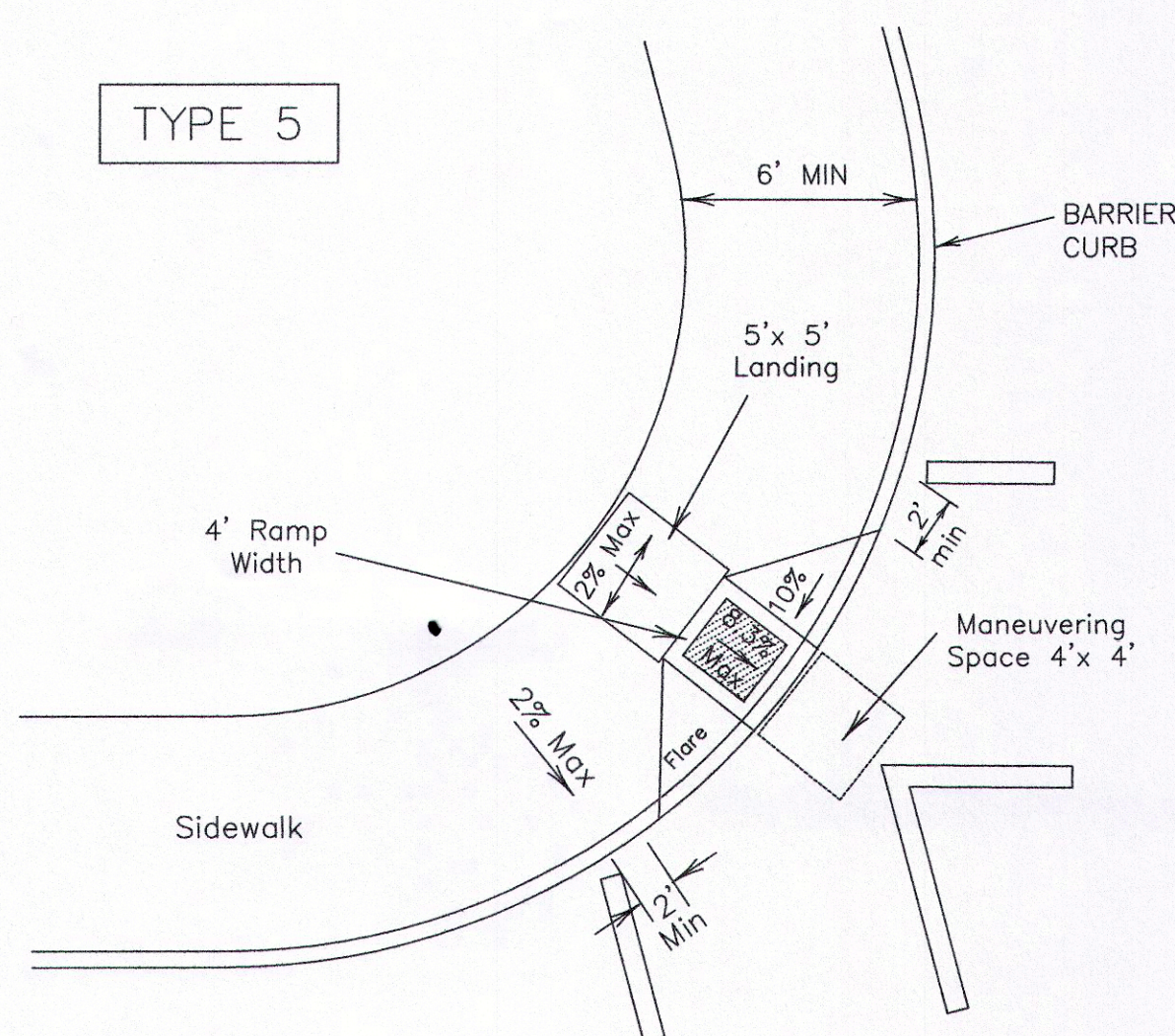

DIAGONAL CURB RAMP (FLARED SIDES)
(PERMISSION FROM CHIEF ENGINEER REQ'D)

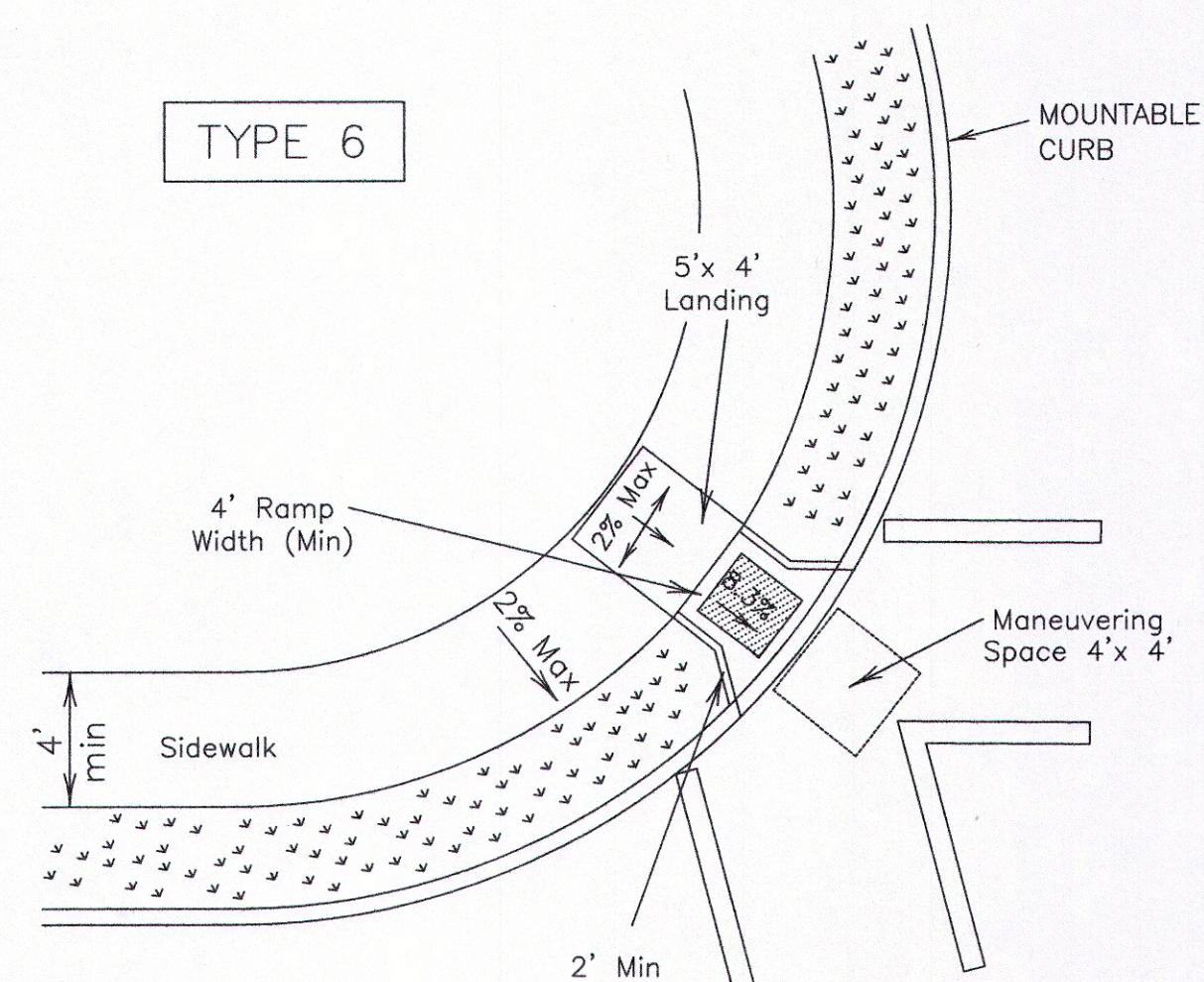

DIAGONAL CURB RAMP (RETURNED CURB)
(PERMISSION FROM CHIEF ENGINEER REQ'D)

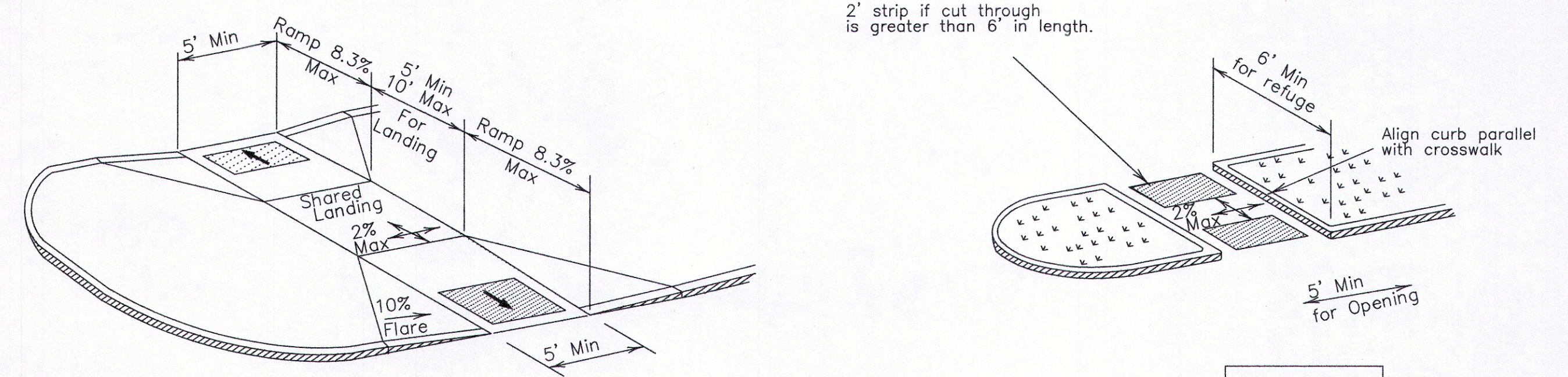

TYPE 7

CURB RAMPS AT MEDIAN ISLANDS

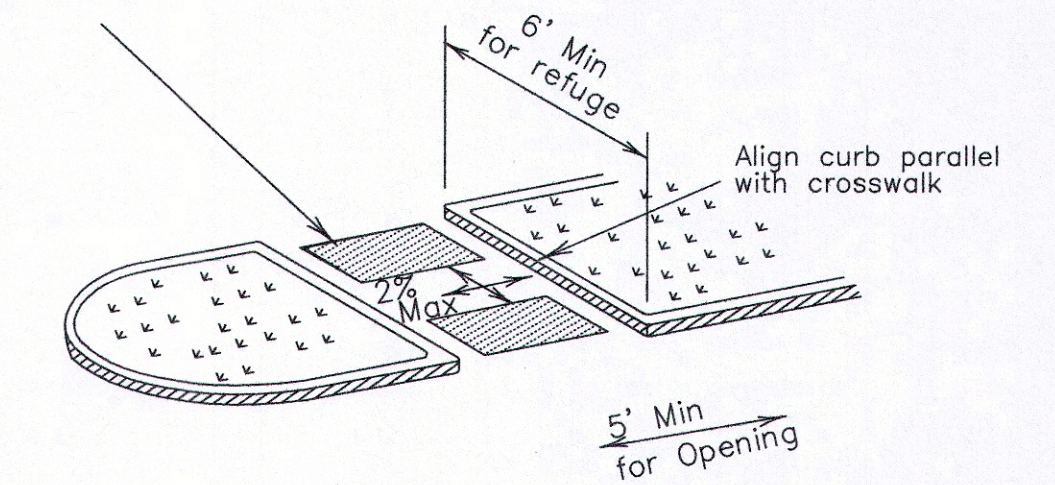

TYPE 8

Detectable warning to be located at Face of Curb for Type 8.

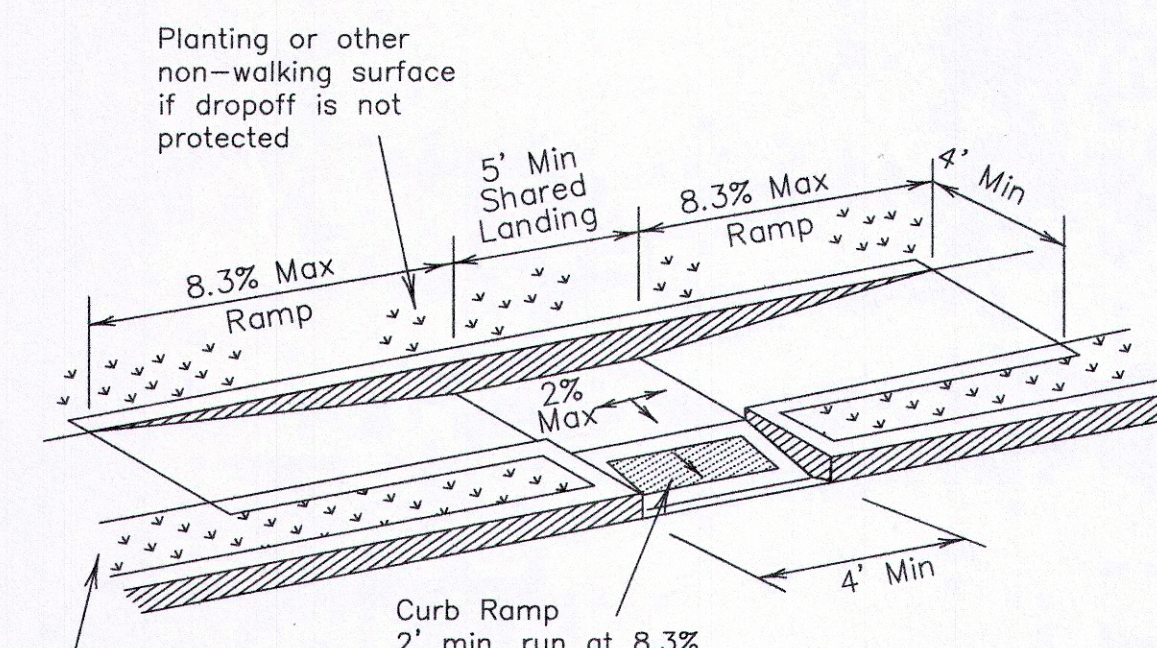

TYPE 9

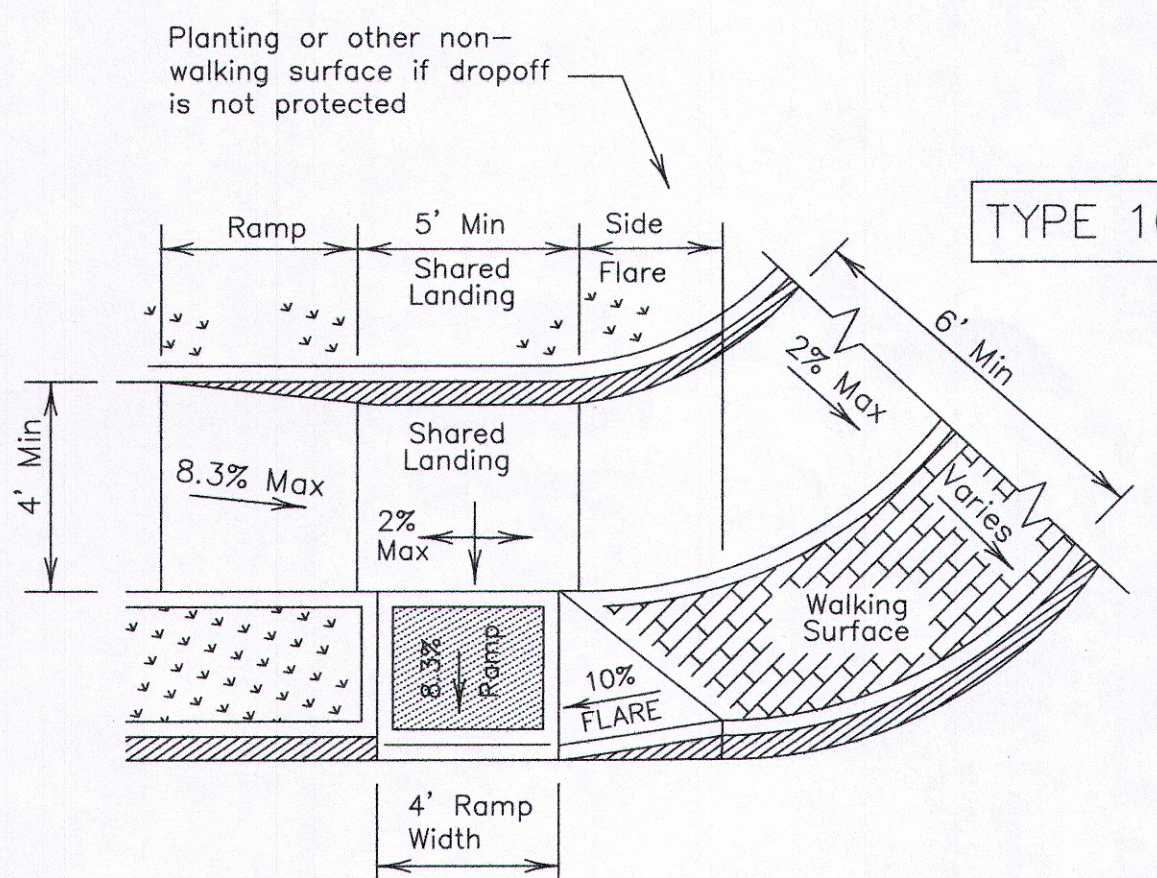

TYPE 10

PERPENDICULAR SIDEWALK RAMP WITH SINGLE FLARE DETAIL

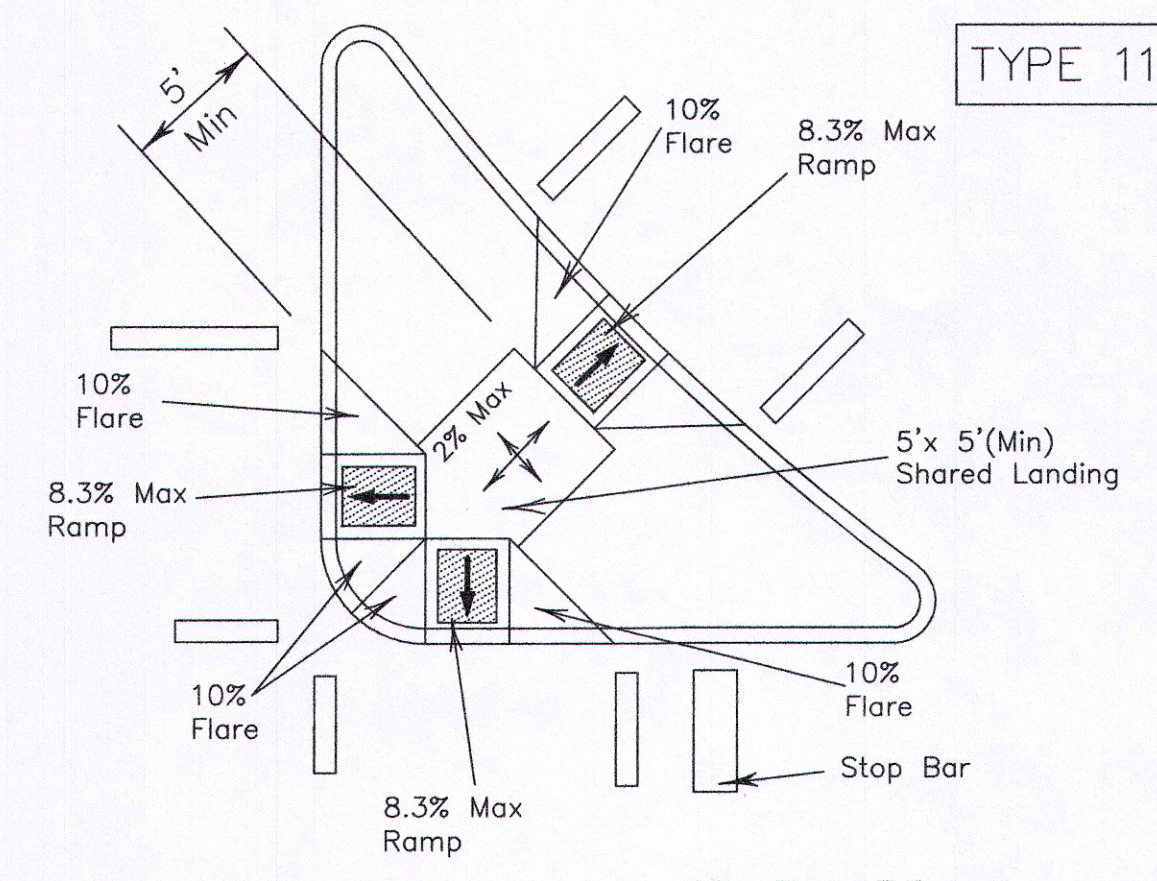

TYPE 11

COMBINATION ISLAND RAMPS

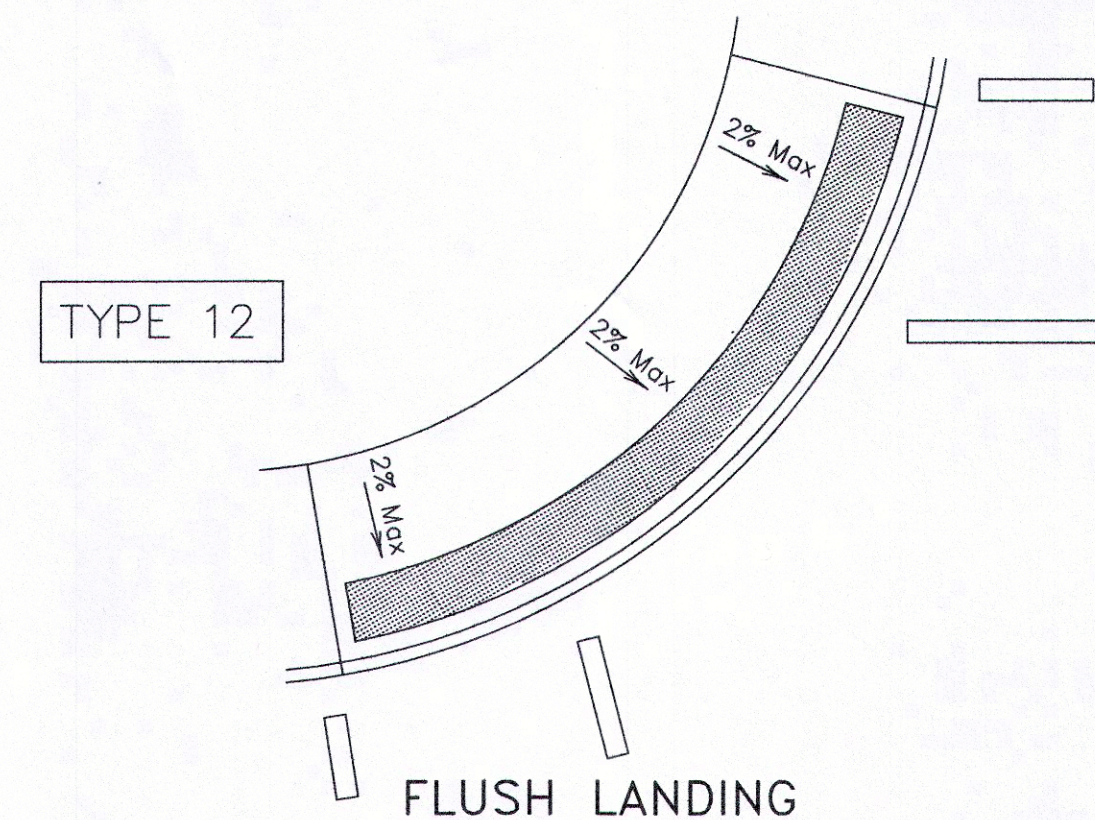

TYPE 12

FLUSH LANDING

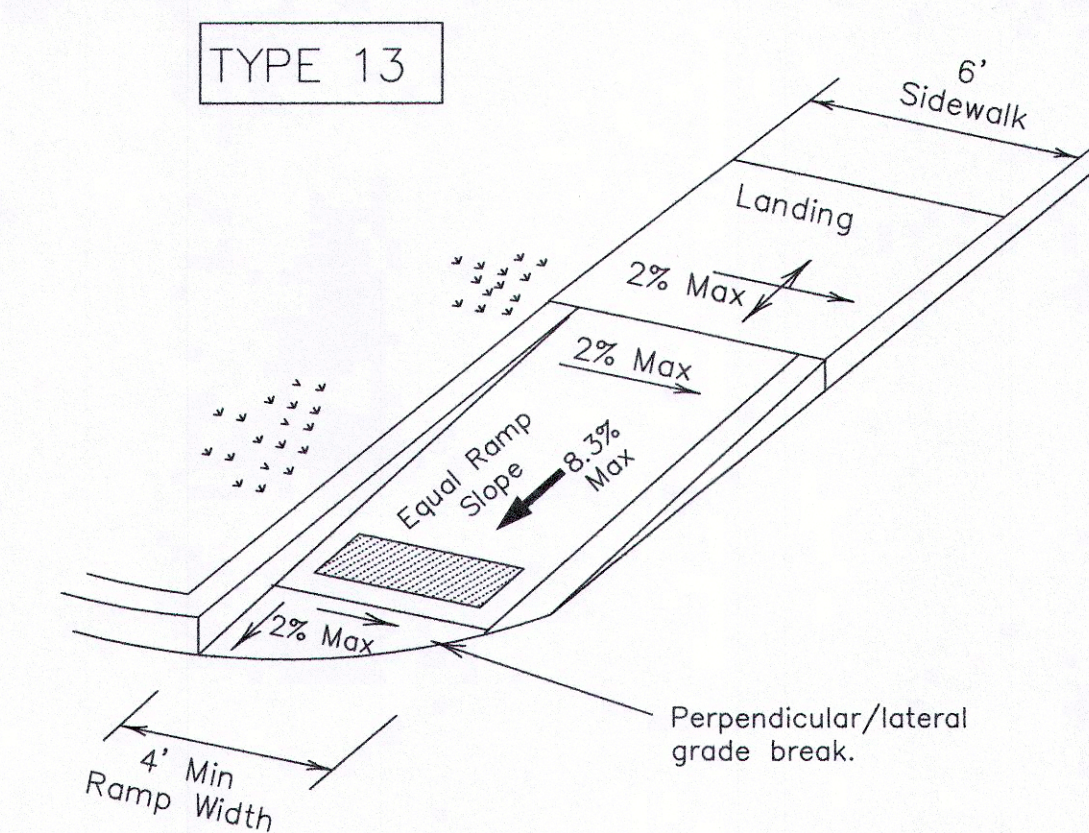

TYPE 13

DIRECTIONAL RAMP WITHIN RADIUS
(Sidewalk adjacent to curb)

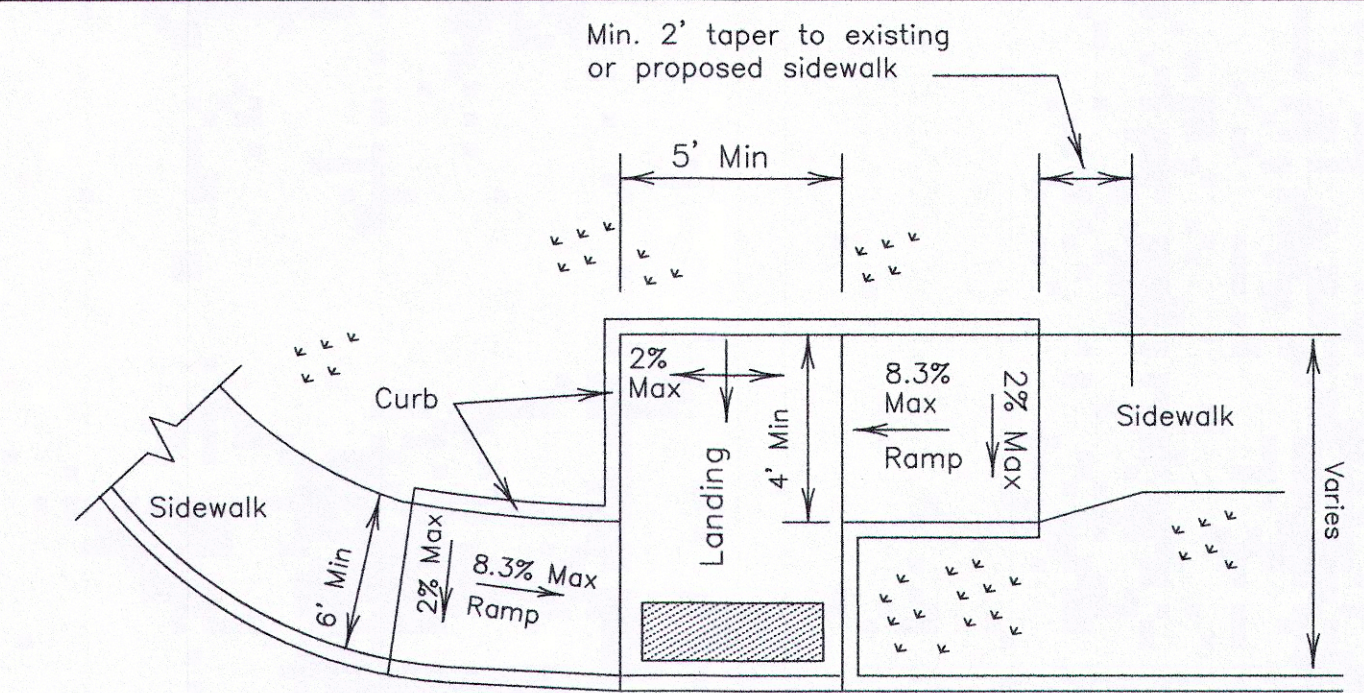

TYPE 14

OFFSET PARALLEL CURB RAMP

- NOTES:
1. See General Notes on sheet ADA2 for more information.
 2. Cross slope not to exceed 2% on any portion of ramp or transition to street.

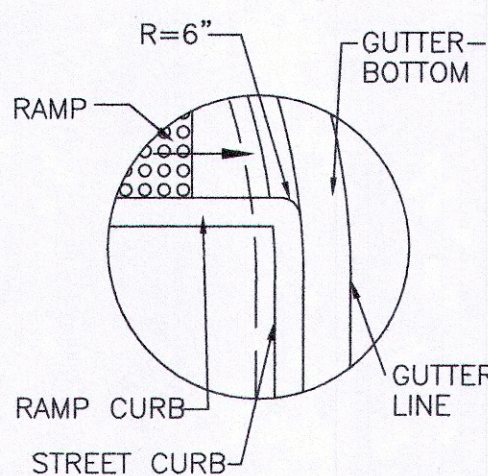

CURB RADIUS DETAIL
N.T.S.

Denotes planting or non-walking surface.

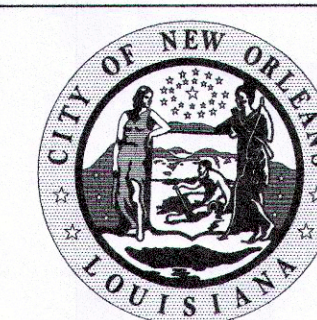

CITY OF NEW ORLEANS
DEPARTMENT OF PUBLIC WORKS
ENGINEERING DIVISION



CURB RAMPS FOR STREET CONSTRUCTION

DRAWING No.

THE SELECTION AND USE OF THESE DETAILS, WHILE DESIGNED IN ACCORDANCE WITH GENERALLY ACCEPTED ENGINEERING PRINCIPLES AND PRACTICES, IS THE SOLE RESPONSIBILITY OF THE USER AND SHOULD NOT BE USED WITHOUT CONSULTING A LOUISIANA REGISTERED PROFESSIONAL ENGINEER.

DRAWN BY: J. LARME
REVIEWED BY: A.Y. L.H. N.S.
RECOMMENDED BY: NGUYEN D. PHAN, CHIEF ENGINEER
DATE: 2/3/2015
SCALE: AS NOTED
APPROVED: MARK D. JEROME, DIRECTOR

ADA1